

MatrixAir Delta

A Modular Roof Mounted Solar Heating System

Patent-pending

Assembly Guide

A simple and effective, roof-mounted solar module for fresh air heating and ventilation

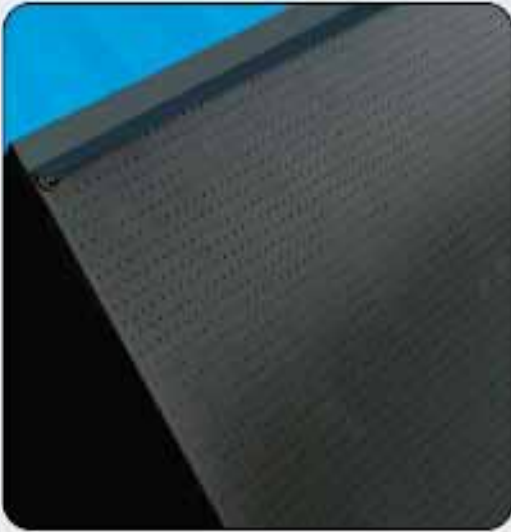

©Matrix Energy Inc. 2009
Tech Guide V7

This guide will show you how to assemble the MatrixAir™ Delta system modules.

Just so we all speak the same language the following definitions are used to describe the various elements of the MatrixAir™ Delta:

A *module* consists of just one unit; a *row* consists of two or more modules connected in series; an *array* consists of modules connected in both series and parallel, a *system* is used to describe the entire final installation consisting of one or more arrays. For example, a 10,000 CFM System consists of two *arrays* each with four *rows* of five *modules* each.

The assembly of the MatrixAir™ Delta array will be dependent on the type of connection chosen: End connection; Bottom Connection; or Mid Connection. The different connection methods are described in the *Technical Guide*.

In this document, Module #1 refers to the module that connects to the ventilation duct. For the End Connection and Mid Connection systems Module #1 will be that which begins the row. For the Bottom Connection method on the other hand, Module #1 is the middle module. The Bottom Connection method has two end modules, one at each end of the row. Prior to beginning assembly of the modules it is important to note the position of the connection to the air handling unit, the Bypass Box and the appropriate ducts to the MatrixAir™ Delta array as specified by the design for your building. For more information refer to the **Design Guide for the MatrixAir™ Delta System**.

Step One - Positioning

Once the positions of all the elements of the system are noted, begin first by connecting the Bypass Box to the air handling unit.

Step Two – Bypass connection

Connect the Bypass Box to the duct which connects to Module #1 in the MatrixAir™ Delta array. Ensure the duct is sized appropriately for the air volume to be delivered by the array to which it is connected so as to minimize pressure or other performance losses.

Step Three – Leg assembly

Assemble the legs of MatrixAir™ Delta module #1. Legs will be identified as

Leg 1, (leg adjacent to the duct)

Leg 2, (located at midpoint of the module)

Leg 3, (the Leg at the end of a row OR the common leg between adjacent modules).

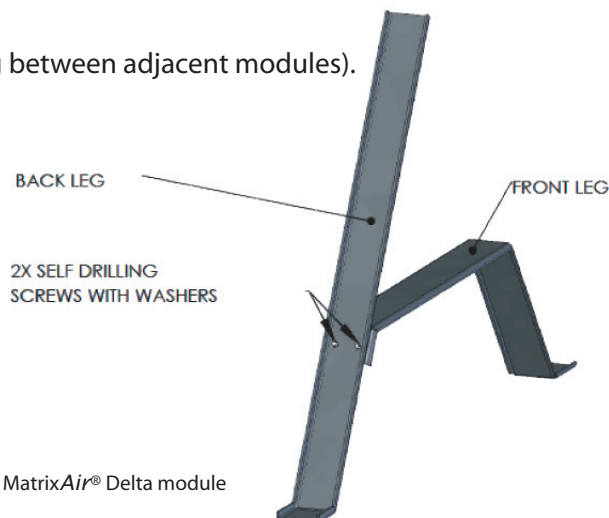

Figure 1: Legs of the MatrixAir® Delta module

MatrixAir™ Delta Assembly Guide

Step Four – Plenum attachment

Attach the Plenum to the legs. The screws should be placed on each leg as shown in Figures 2 and 3 from the inside to the outside of the plenum. Module #1 will resemble the image in Detail A of Figure 6 assuming the duct will be connected on the right hand side using either the End Connection or the Mid Connection. For the Bottom Connection methods module #1 will resemble Detail A of Figure 7.

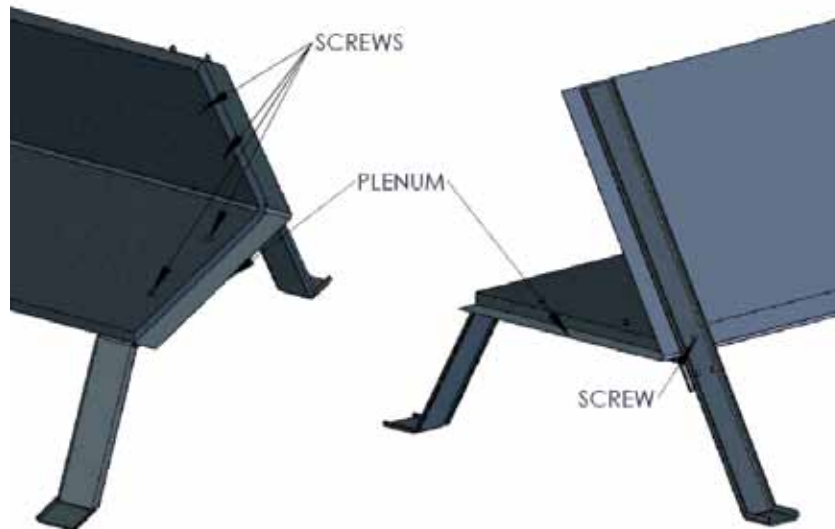

Figure 2: Plenum attached from front

Figure 3: Plenum attached from back

The legs must be leveled and aligned usually 60 inches center to center. At the start of the row with Module #1 when using the End Connection or the Mid Connection (see “Connection Methods” in the Technical Guide), reduce the space by 3.5 inches to 56.5 inches from the middle leg to the end leg. For the Bottom Connection method leave 60 inches between all the legs for Module #1. See Figures 4 and 5 below.

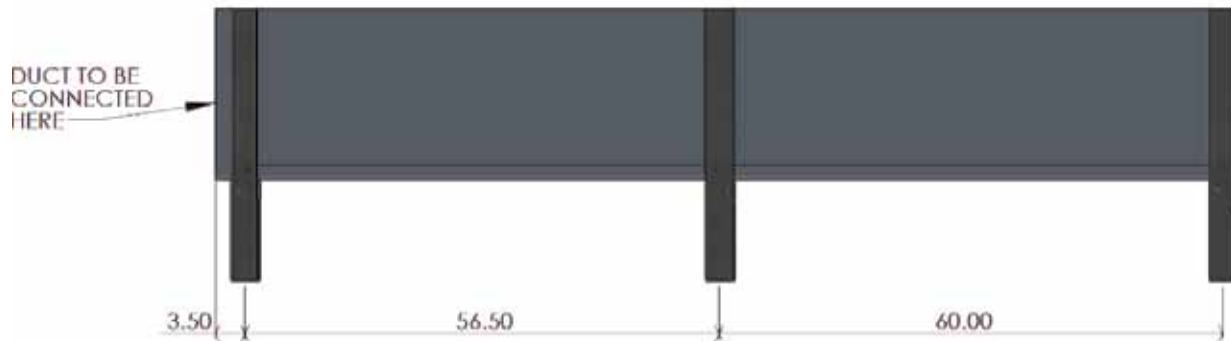

Figure 4: Distances between the legs for module #1 using the End Connection or Mid Connection



Figure 5: Distances between the legs for Module #1 using the Bottom Connection

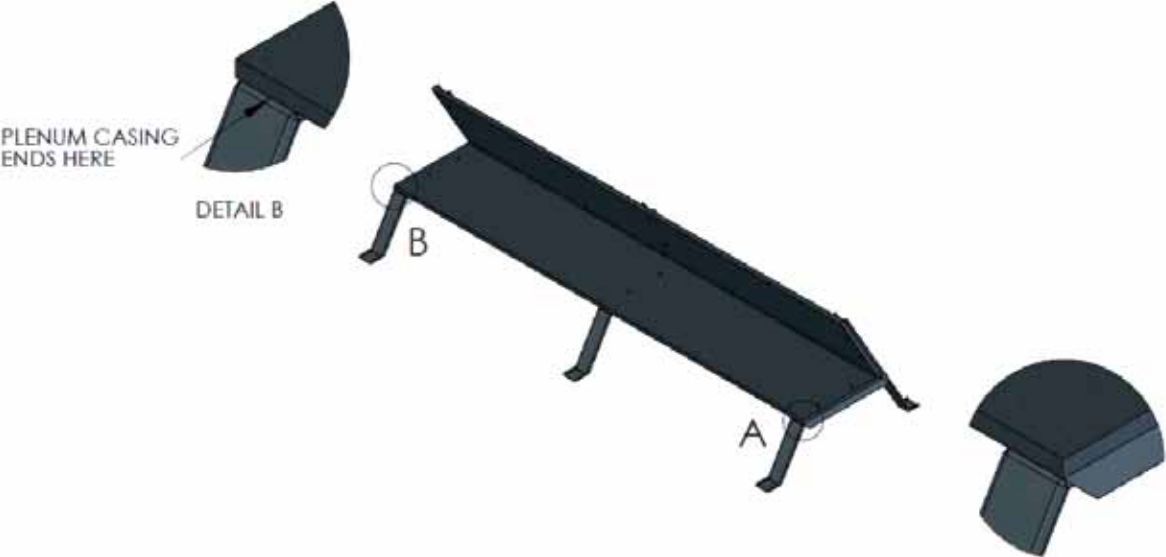

Figure 6: Isometric view of the Plenum attached connection on right **DETAIL A**



Figure 7: Isometric view of the Plenum attached for Bottom Connection

Step 4.a. – Bottom Connection Opening

When using the Bottom Connection there is an extra step. An opening will need to be made in the Plenum as shown in Figure 8. The opening must be big enough to accommodate the duct at the bottom as shown in Figure 9. Opening dimensions are based on the expected air flow from each row according to the number of modules in that row.

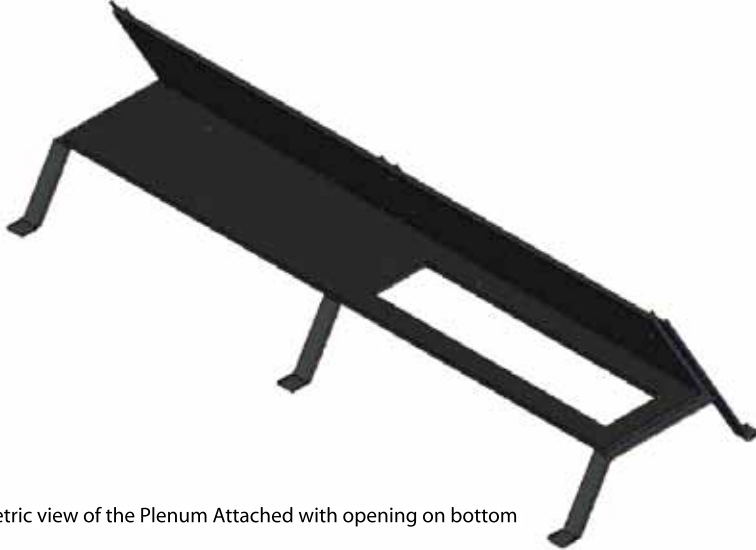

Figure 8: Isometric view of the Plenum Attached with opening on bottom

Modules per row	Opening Dimensions
1 - 4	18" x 12"
5 - 8	36" x 12"
9 - 14	50" x 14"

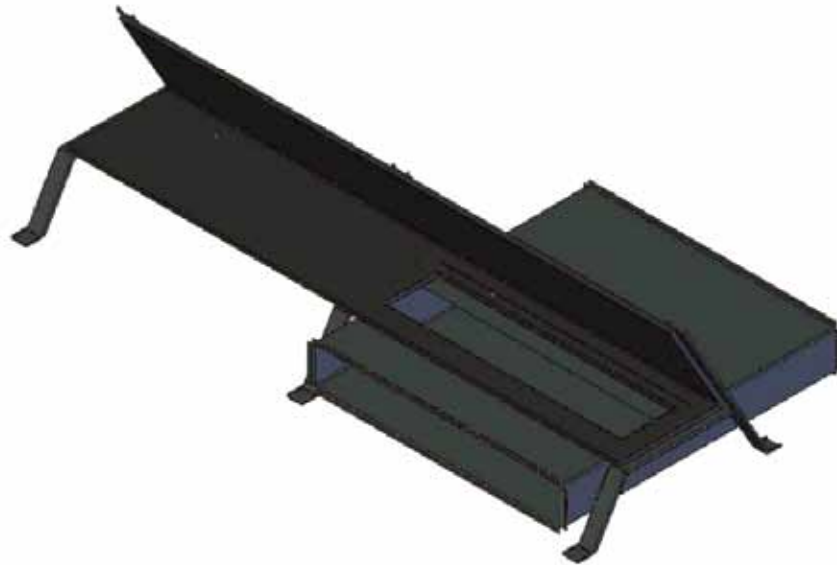

Figure 9: Plenum attached with Bottom Connection duct

Step Five - Attaching the Collector to the Plenum

IMPORTANT: Ensure that Collector is installed with the air outlet openings on the bottom and that the openings are located towards the duct end of each row (closest to the air handling unit). See Figure 12.

The Collector is inserted into the Plenum as shown in Figure 10. At this point the plenum should be screwed to the bottom of the collector only. The screws should be approximately fifteen inches apart as shown in Figure 11. Three screws should be fastened onto each of the legs going from the leg to the plenum and then through the collector.

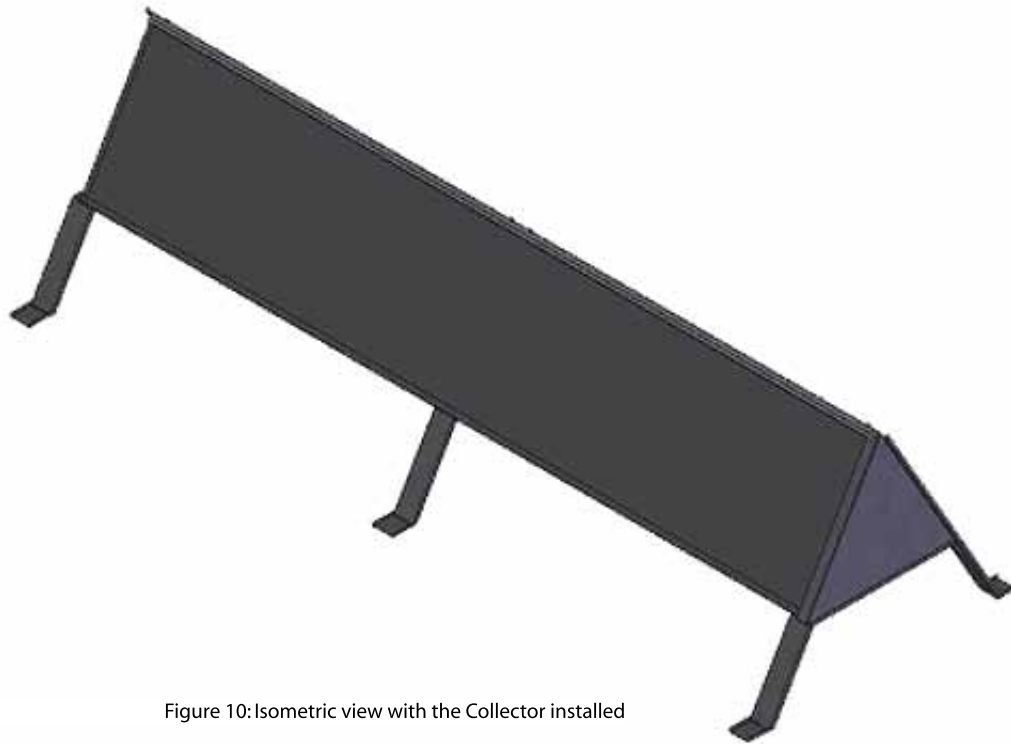

Figure 10: Isometric view with the Collector installed

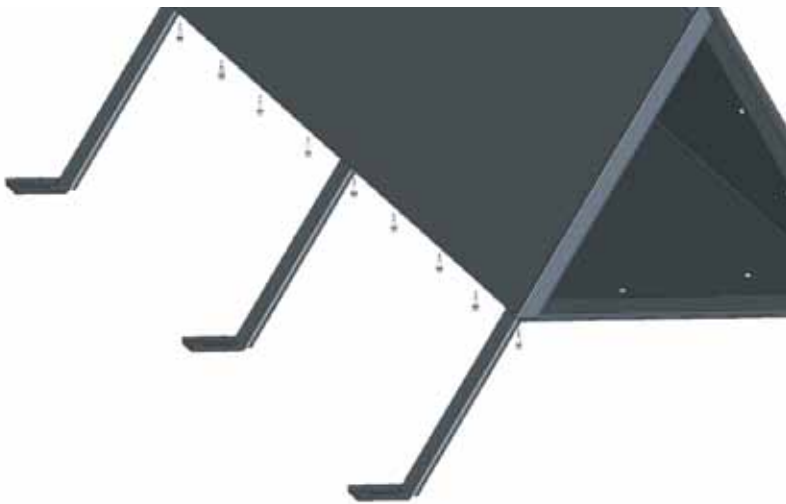

Figure 11: Screws from under Plenum

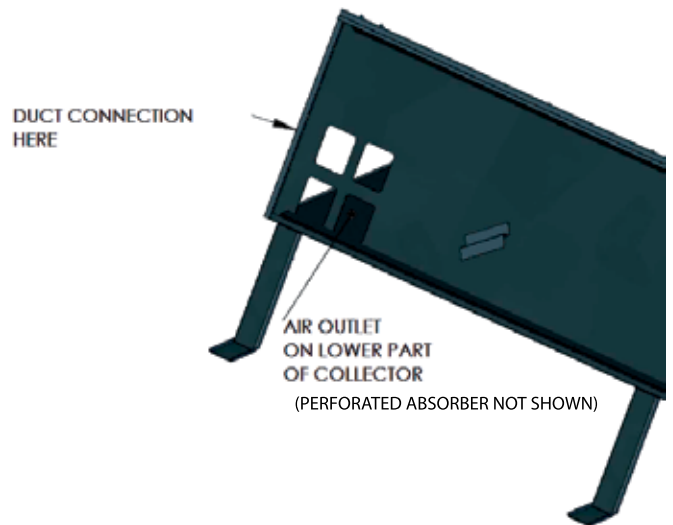

Figure 12: Picture with Absorber Plate removed from Collector to show air outlet

Step Six - Attach the Top Flashing to the plenum and the collector

At the start of a row install the shorter, five foot long Top Flashing. The Top Flashing should be screwed as shown in Figure 13.

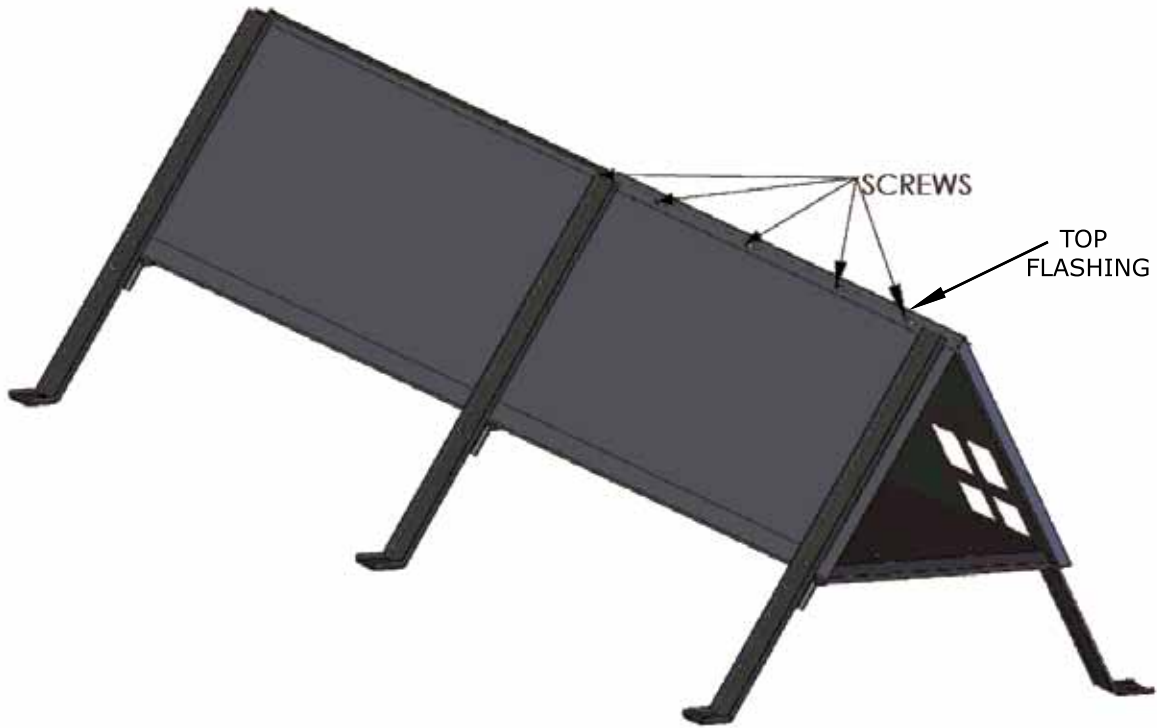

Figure 13: Top Flashing attached

Module #1 is now assembled; we can now start to assemble the rest of the modules in the row.

Step Seven – Adding Modules

For module #2 assemble two sets of legs as shown in Figure 1. Once the legs are assembled place leg #2 (middle) at a distance of five feet center to center from the last leg (#3) of the first module. And the other leg at a distance of five feet from leg #2. Make sure that the legs are properly aligned and level.

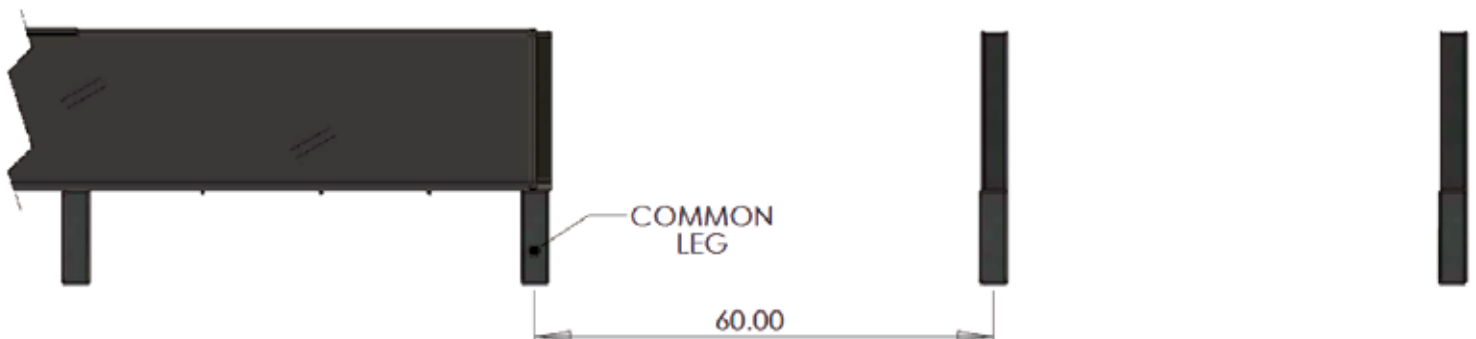

Figure 14: Legs aligned for next module

Step Eight – Plenum addition

Attach another plenum to the legs as done in step 4. The plenums of two different modules will be supported by a common leg as shown in Figure 15.

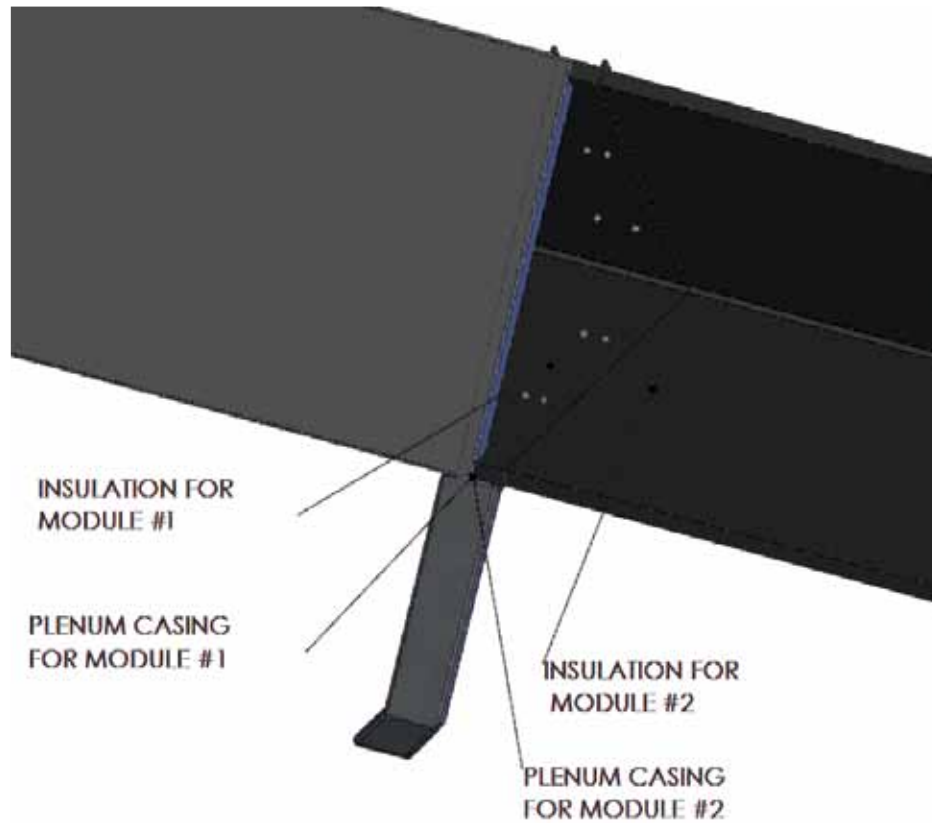

Figure 15: Top Flashing attached

Step Nine – Collector addition

Attach a second collector as done in Step 6. First only screw from the bottom, then add the top flashing, at this point use the 10 foot long Top Flashing and fasten it from behind as shown in Figure 13.

Apply caulking to joint between modules to ensure air tightness.

Step 10

Repeat the previous steps until you reach the number of modules indicated in your design. When using the Bottom Connection method, assemble one module to the left of module #1 and then to the right and continue in that manner.

Step 11

The assembly of the last module in a row will be slightly different. Instead of leaving 60 inches between the middle leg and the last leg, leave a distance of 56.5 inches center to center. Also instead of using a 10 foot long Top Flashing, use a 5 foot long Top Flashing.

Step 12

At the end of a row insert the End Cap as shown in Figure 16. There should be two screws on each flange of the end cap. Apply caulking to end cap to ensure an air tight seal.